

Generator set

Sound-proof type

GMS80C6S

SPECIFICATIONS

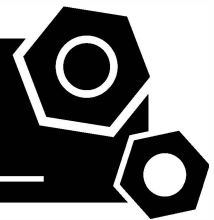

1 Standards & Conditions

Design Standards

The designs and the productions are in conformity with:

- Conformance Européenne (CE)
- ISO8528-5:2005
- GB/T2820.5-2009

Environmental Operating Conditions

- Installation place: Outdoors or indoors (well ventilated).
- Ambient temperature: -25°C to 45°C. The coolant heater is needed when the temperature is below 5°C
- Humidity: Less than 80%.
- Altitude: Below one thousand (1000) meters.

Factory Inspection

- Inspection items.
- Protection devices working test.
- Starting ability in normal temperature.
- 50% rated power load moment capability.
- Voltage deviation and speed variation: 0%, 25%, 50%, 75%, 100%, 110% Load.

Painting Process

- Painting process specifications and colors are based on the manufacturer's standard.
- The customer could also choose the color which the manufacturer offers.

2 General Features

- Cummins engine 4BTA3.9-G11
- Close coupled to Leroy-somer alternator LSA44.3S4
- Microprocessor control module PLC-7420
- Main circuit breaker: 250
- Rotate speed governor: Electrical governor
- Excitation system: Self excited
- A.V.R model: R250
- Key switch
- Emergency stop switch
- ATS (automatic transfer switch) receptacle
- 2x12V/70AH sealed for life maintenance free battery

- Lockable battery isolator switch
- Powder coated canopy
- 50°C radiator
- Oil pump on the engine
- Steel base frame with forklift channel
- Vibration isolators between the engine/alternator and base frame
- Dry type air filter
- Base fuel tank for 10 hours running
- Drain points for fuel tank
- Operation Manual / Specifications

3 Equipment

General technical data

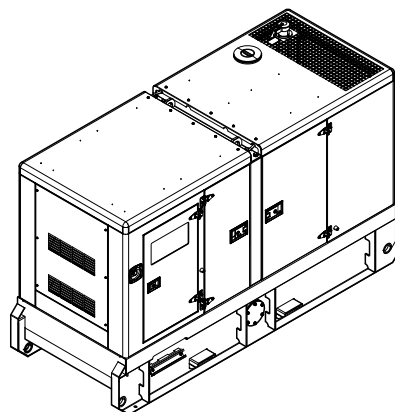

Model.....GMS80C6S
 Structure type R
 Tank capacity.....220L
 Dry weigh..... 1852kg
 Noise level @7m 69.2dBA
 Dimensions L×W×H.....2888x1128x1692mm
 Standby Power 99kVA/79kW
 Prime Power 90kVA/72kW

Voltage	208V	220V	230V	240V	
Ampere	249.8A	236.2A	225.9A	216.5A	
Genset Fuel Consumption					
Frequency/Load	25%	50%	75%	100%	110%
60Hz (L/h)	6.4	10.8	15.3	20.1	22.5

Diesel engine

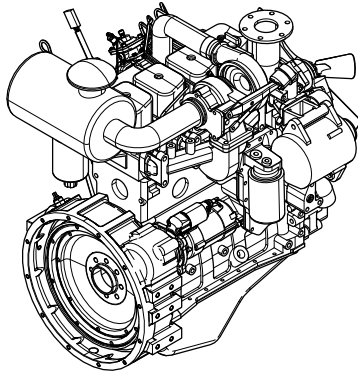

Engine Manufacturer/Brand	Cummins
Engine Model	4BTA3.9G11
Dimensions L×W×H.....	884.9*748.4*985.6
Dry Weigh (approx.)	350kg
Number of Cylinders	4
Bore	102mm
Stroke	120mm
Displacement.....	3.9L
Compression Ratio	17.3
Type of injection.....	Direct injection
Intake System.....	Turbocharged,water-to-air charge cooled
Intake Resistance	≤ 6.28kPa
Cooling System	Water cooled
Fan	Pusher
Battery Voltage	12/24V
Type of Fuel.....	Diesel
Type of Oil	15W40-CH4
Oil Capacity	9.5L
Type of Coolant	Glycol mixture
Coolant Capacity	20.8L
Back Pressure	≤10.1kPa
Standby Power	90kW
Prime Power	80kW
Fuel Consumption(100%load)	207g/kW.h

Alternator

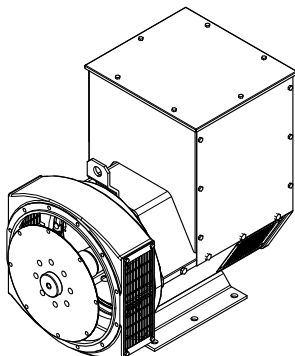

Alternator Manufacturer/Brand	Leroy-somer
Alternator Model	LSA44.3S4
Exciter.....	Brushless
Cooling Fan	Cast alloy aluminum
Windings.....	100% copper
Insulation Class	H
Winding Pitch.....	2/3
Terminals	12
Drip Proof	IP23
Altitude.....	≤1000m
Overspeed	2250 rpm
Air Flow.....	0.216m³/s(50HZ),0.281m³/s(60HZ)
Voltage Regulation	±1.0%
Total harmonic TGH / THCat no load < 1.5 % - on load < 5%	
Telephone Interference.....	THF<2%;TIF<50

PLC-7420 Control System

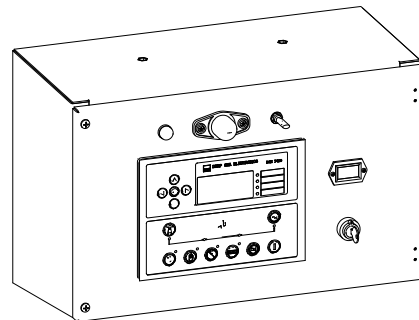

PLC-7420 is an advanced control module based on micro-processor, containing all necessary functions for protection of the genset and the breaker control. It can monitor the mains supply, and automatically start the engine when the mains is abnormal. Accurately measure various operational parameters and display all values and alarms information on the LCD. In addition, the control module can automatically shut down the engine and indicate the engine failure.

- Microprocessor control, with high stability and credibility
- Monitoring and measuring operational parameters of the mains supply and genset
- Indicating operation status, fault conditions, all parameters and alarms
- Multiple protections; multiple parameters display, like pressure, temp. etc.
- Manual, automatic and remote work mode selectable
- Real time clock for time and date display, overall runtime display, 250 log entries
- Overall power output display
- Integral speed/frequency detecting, telling status of start, rated operation, overspeed etc.
- Communication with PC via RS485 OR RS232 interface, using MODBUS protocol

4 Overall Dimensions

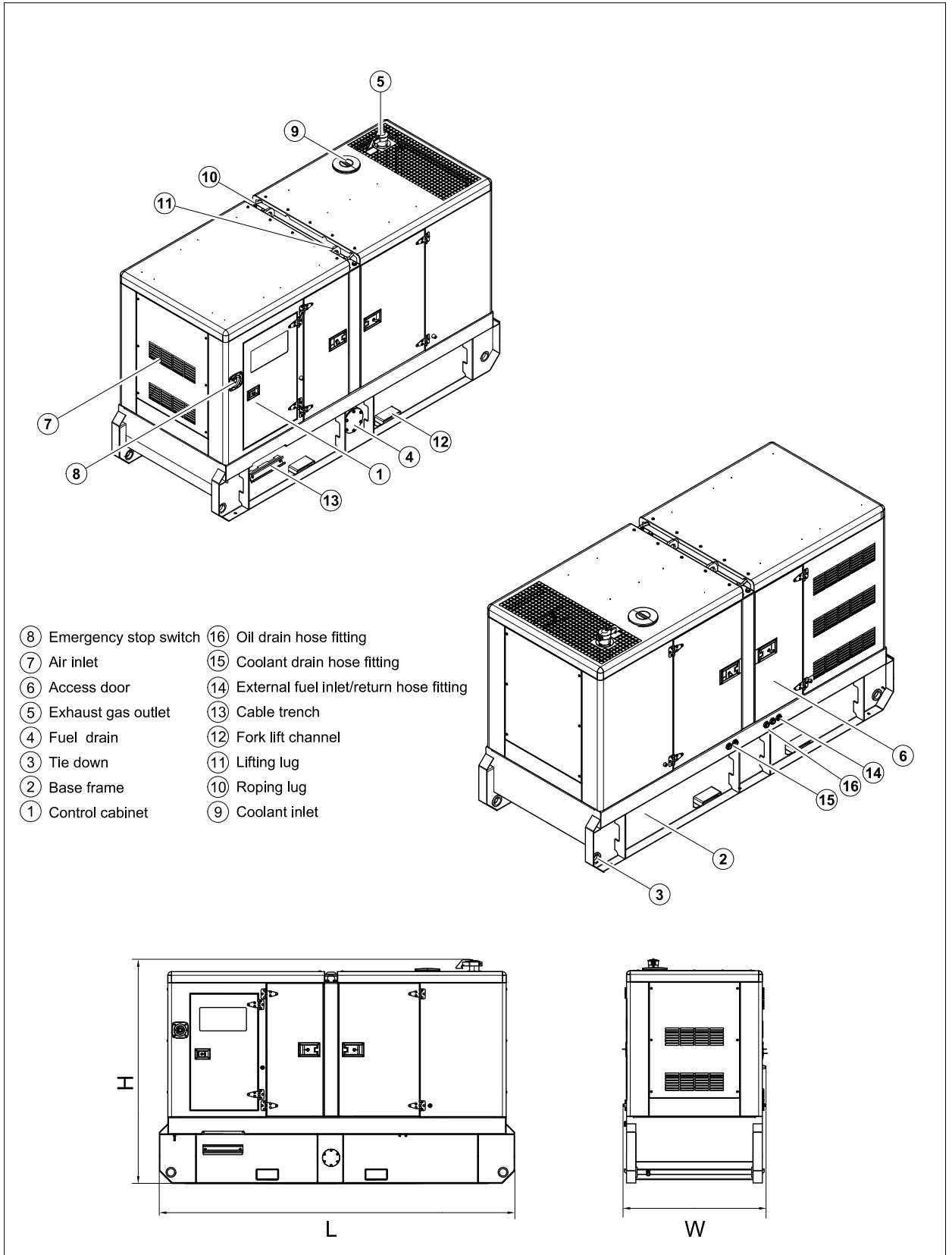

5 Control System

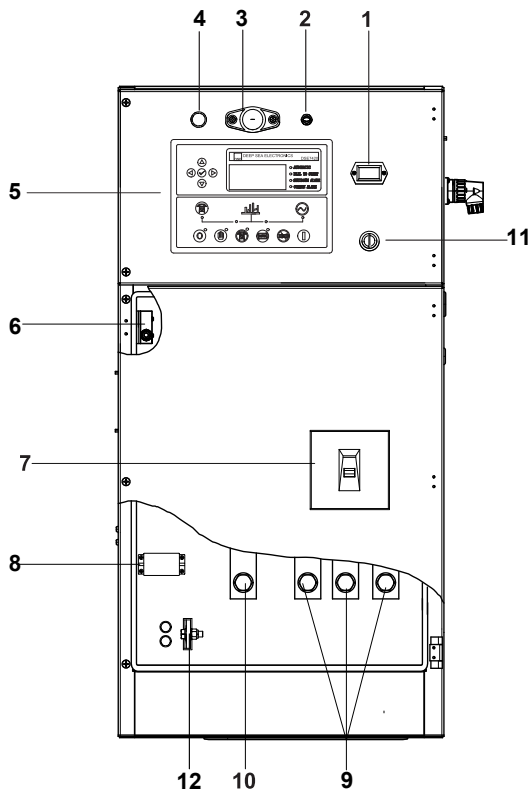

Control & field wiring cabinet

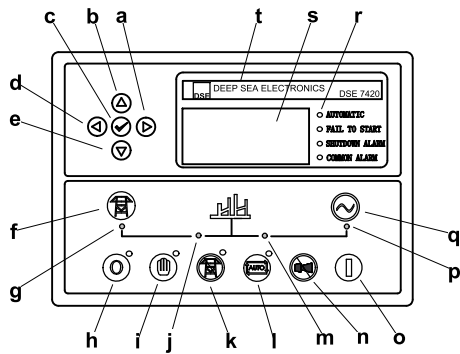

Control module

Ref.	Description
1	Time counter
2	Control panel lamp switch
3	Control panel lamp
4	Charge indicator
5	Control module
6	Limit switch
7	Main circuit breaker
8	Mains input/ remote/AMF communication connector
9	Live wire terminals
10	Neutral wire terminal
11	Key switch
12	Ground wire terminal

a	Button (next page)
b	Button (increase value / previous item)
c	Button (accept)
d	Button (previous page)
e	Button (decrease value / next item)
f	Button (transfer the load to the mains supply, when in Manual mode only)
g	Mains supply available LED
h	Stop / Reset button
i	Manual button (Manual control mode)
j	Mains supply on load LED
k	Test button (Test mode)
l	Auto button (Auto mode)
m	Genset on load LED
n	Mute/Lamp test button
o	Start button (Manual)
p	Genset available LED
q	Button (transfer the load to the genset, when in Manual mode only)
r	Alarm LED (4 alarm items)
s	LCD display
t	Control module name

100029749-A2-E

07.2023

<http://www.powerlinkworld.com>

*Specification may change without prior notice. For more info.,
contact Power Link or your local distributors please.*