

**Generator set**  
**Sound-proof type**  
**GMS100CS**

# **SPECIFICATIONS**

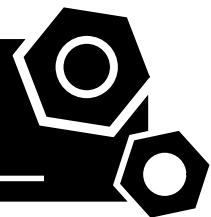

## 1 Standards & Conditions

### Design Standards

The designs and the productions are in conformity with:

- Conformance Européenne (CE)
- ISO8528-5:2005
- GB/T2820.5-2009

### Environmental Operating Conditions

- Installation place: Outdoors or indoors (well ventilated).
- Ambient temperature: -25°C to 45°C. The coolant heater is needed when the temperature is below 5°C
- Humidity: Less than 80%.
- Altitude: Below one thousand (1000) meters.

### Factory Inspection

- Inspection items.
- Protection devices working test.
- Starting ability in normal temperature.
- 50% rated power load moment capability.
- Voltage deviation and speed variation: 0%, 25%, 50%, 75%, 100%, 110% Load.

### Painting Process

- Painting process specifications and colors are based on the manufacturer's standard.
- The customer could also choose the color which the manufacturer offers.

## 2 General Features

- Cummins engine 6BT5.9G2
- Close coupled to LSA alternator LSA44.3S5
- Microprocessor control module PLC-920
- Main circuit breaker: 160A
- Rotate speed governor: EFC
- Excitation System: Self excited
- A.V.R.Model: R250
- Key switch
- Emergency stop switch
- ATS (automatic transfer switch) receptacle
- 2x12V/70AH sealed for life maintenance free battery

- Lockable battery isolator switch
- Powder coated canopy
- 50°C radiator
- Oil pump on the engine
- Steel base frame with forklifts
- Vibration isolators between the engine/alternator and base frame
- Dry type air filter
- Base fuel tank for 24 hours running
- Drain points for fuel tank
- Operation Manual / Specifications

## 3 Equipment Specification

### General technical data

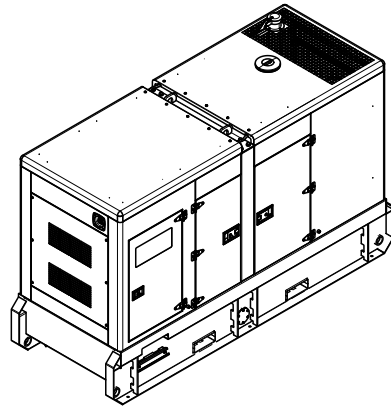

Model.....	GMS100CS
Structure type .....	R
Tank capacity.....	540L
Dry weigh.....	2165kg
Noise level @7m .....	70.2dBA
Dimensions L×W×H.....	3162x1172x1974mm
Standby Power .....	110kVA/88kW
Prime Power .....	100kVA/80kW

Voltage	380V	400V	415V		
Ampere	151.9A	144.3A	139.1A		
<b>Genset Fuel Consumption</b>					
Frequency/Load	25%	50%	75%	100%	110%
50Hz (L/h)	7.0	11.0	17.0	22.0	25.0

## Diesel Engine

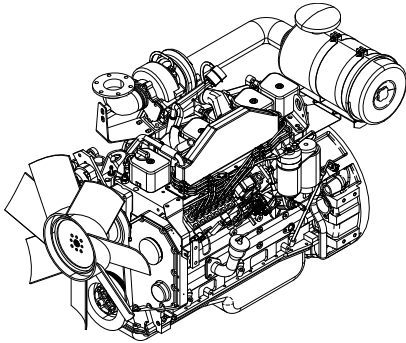

Engine Manufacturer/Brand .....	Cummins
Engine Model .....	6BT5.9G2
Dimensions L×W×H.....	1198*716.8*1008
Dry Weigh (approx.) .....	411kg
Number of Cylinders.....	6
Bore .....	102mm
Stroke .....	120mm
Displacement.....	5.9L
Compression Ratio .....	16.8
Type of injection.....	Direct injection
Intake System.....	Turbocharged, air-to-air charge cooled
Intake Resistance .....	≤6.28kPa
Cooling System .....	Water cooled
Fan .....	Pusher
Battery Voltage .....	12/24V
Type of Fuel.....	Diesel
Type of Oil .....	15W40-CF4
Oil Capacity .....	14.2L
Type of Coolant .....	Glycol mixture
Coolant Capacity .....	20.8L
Back Pressure .....	≤10.1kPa
Fuel Consumption(100%load).....	214g/kW.h

Frequency	Standby Power	Prime Power
50Hz	80kW	80kW

## Alternator

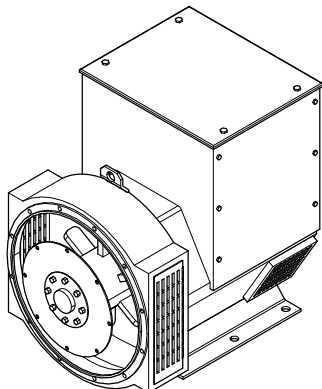

Alternator Manufacturer/Brand .....	LSA
Alternator Model .....	LSA44.3S5
Exciter.....	Brushless
Cooling Fan .....	Cast alloy aluminum
Windings.....	100% copper
Insulation Class .....	H
Winding Pitch.....	2/3
Terminals .....	12
Drip Proof .....	IP23
Altitude.....	≤1000m
Overspeed .....	2250 rpm
Air Flow.....	0.514m³/s(50HZ),0.617m³/s(60HZ)
Voltage Regulation .....	±1.0%
Total harmonic TGH / THCat no load < 1.5 % - on load < 5%	
Telephone Interference.....	THF<2%;TIF<50

## PLC-920 Control System

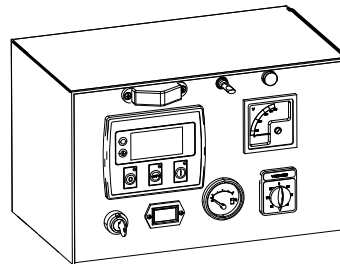

PLC-920 is an advanced control module based on micro-processor designed to control the engine via a key switch and push buttons on the front panel. The module is used to start and stop the engine and indicate fault conditions, automatically shutting down the engine and giving a true up fault condition of an engine failure.

### Standard Control Function

- Manual Engine Control Module
- Low Oil Pressure
- High Engine Temperature
- Auxiliary Shutdown
- Overspeed Protection
- Protection hold-off timer
- Charge Failure warning

## 4 Overall Dimensions

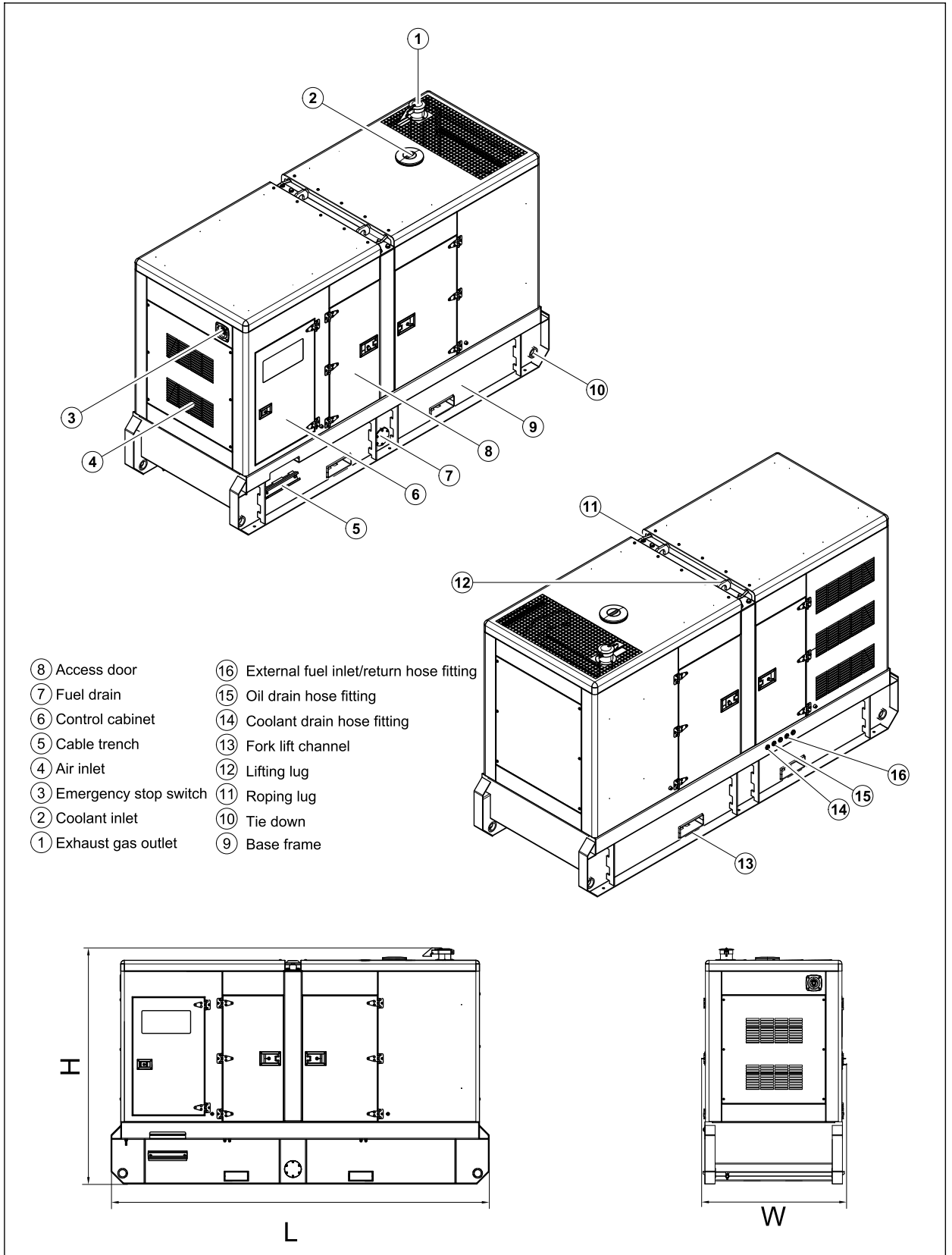

## 5 Control System

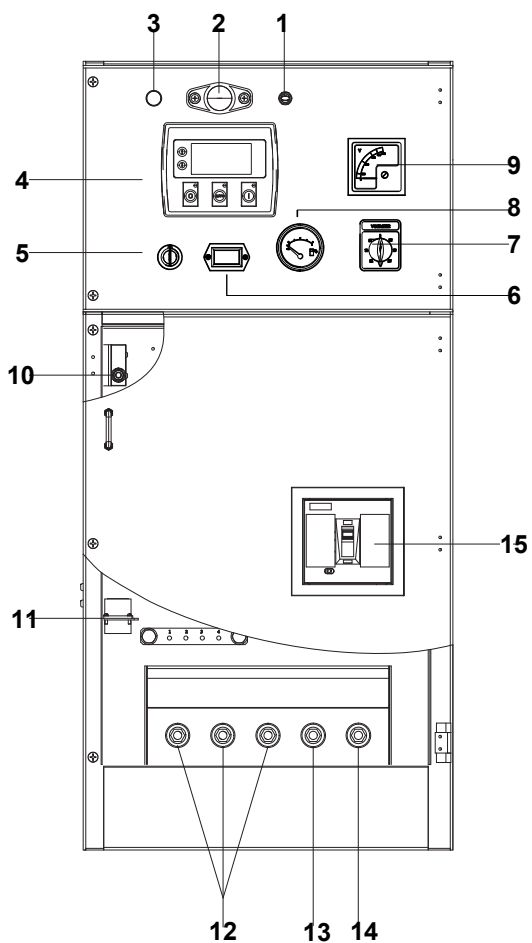

**Control & field wiring cabinet**

Ref.	Description
1	Control cabinet lamp switch
2	Control cabinet lamp
3	Charge indicator
4	Control module
5	Key switch
6	Time counter
7	Voltage changer-over switch
8	Fuel level meter
9	Voltage meter
10	Limit switch
11	Mains input/Remote control/ATS connector
12	Live wire terminal
13	Neutral wire terminal
14	Ground wire terminal
15	Main circuit breaker

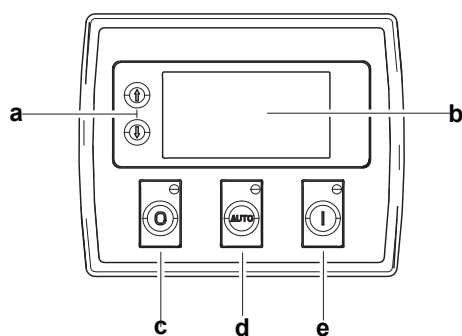

**Control module**

Ref.	Description
a	Navigation button«» Accept (Configuration mode only)
b	Main status display
c	Stop/reset button«» Next page (Configuration mode only)
d	Auto start button«» Decrease value/next item (Configuration mode only)
e	Start button«» Increase value/next item (Configuration mode only)

1000029544-A1-E
-----------------

10.2023
---------

<http://www.powerlinkworld.com>

*Specification may change without prior notice. For more info.,  
contact Power Link or your local distributors please.*