

Generator set
Sound-proof type
GMS180CS

SPECIFICATIONS

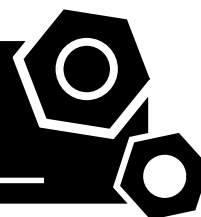

1 Standards & Conditions

Design Standards

The designs and the productions are in conformity with:

- Conformance Européenne (CE)
- ISO8528-5:2005
- GB/T2820.5-2009

Environmental Operating Conditions

- Installation place: Outdoors or indoors (well ventilated).
- Ambient temperature: -25°C to 45°C. The coolant heater is needed when the temperature is below 5°C
- Humidity: Less than 80%.
- Altitude: Below one thousand (1000) meters above sea Level.

Factory Inspection

- Inspection items.
- Protection devices working test.
- Starting ability in normal temperature.
- 50% rated power load moment capability.
- Voltage deviation and speed variation: 0%, 25%, 50%, 75%, 100%, 110% Load.

Painting Process

- Painting process specifications and colors are based on the manufacturer's standard.
- The customer could also choose the color which the manufacturer offers.

2 General Features

- Cummins engine 6CTA8.3-G2
- Close coupled to LSA alternator LSA44.3VL13
- Microprocessor control module PLC-920
- Main circuit breaker: 320A
- Rotate speed governor: EFC
- Excitation system: Self excited
- A.V.R model: R250
- Key switch

- Emergency stop switch
- ATS (automatic transfer switch) receptacle
- 2x12V sealed for life maintenance free battery
- Lockable battery isolator switch
- Powder coated canopy
- 50°C radiator
- Oil pump on the engine
- Steel base frame with forklifts
- Vibration isolators between the engine/alternator and base frame
- Dry type air filter
- Base fuel tank for 10 hours running
- Drain points for fuel tank
- Operation Manual / Parts List/ Specifications

3 Equipment Specification

General technical data

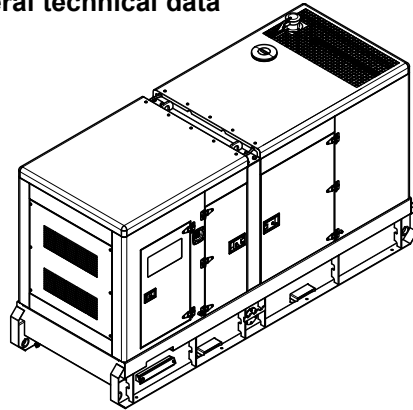

Model.....	GMS180CS
Structure type	R
Tank capacity.....	420L
Dry weight.....	2629kg
Noise level @7m	72.5dBA
Dimensions L×W×H.....	3438x1300x1868mm
Standby Power	198kVA/158kW
Prime Power	180kVA/144kW

Voltage	380V	400V	415V	440V	
Ampere	273.4A	260.0A	250.4A	236.2A	
Genset Fuel Consumption					
Frequency/Load	25%	50%	75%	100%	110%
50Hz (L/h)	13	21	31	42	48

Diesel Engine

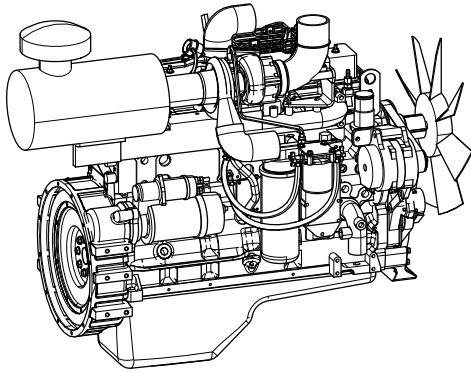

Engine Manufacturer/Brand	Cummins
Engine Model	6CTA8.3-G2
Dimensions L×W×H.....	N/A
Dry Weigh (approx.)	637kg
Number of Cylinders.....	6
Bore.....	114mm
Stroke	135mm
Displacement.....	8.3L
Compression Ratio	17.3
Type of injection.....	Direct injection
Intake System.....	Jacket water Aftercooled
Intake Resistance	≤6.28kPa
Cooling System	Water cooled
Fan	Pusher
Battery Voltage	24V
Type of Fuel.....	Diesel
Type of Oil	ACEA E2, API CF, CF-4, CG-4
Oil Capacity	10.9L
Type of Coolant	Glycol mixture
Coolant Capacity(Engine Only)	12.3L
Back Pressure	≤10.1kPa
Standby Power	180kW
Continuous Power	163kW
Fuel Consumption(100%load).....	212g/kW.h

Alternator

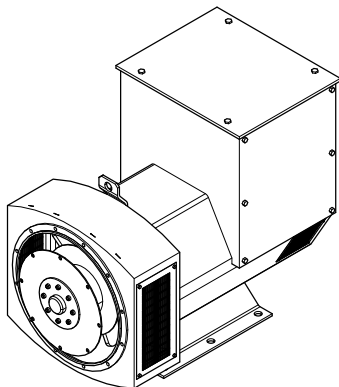

Alternator Manufacturer/Brand	LSA
Alternator Model	LSA44.3VL13
Exciter.....	Brushless
Cooling Fan	Cast alloy aluminum
Windings.....	100% copper
Insulation Class	H
Winding Pitch.....	2/3
Terminals	12
Drip Proof	IP23
Altitude.....	≤1000m
Overspeed	2250rpm
Air Flow.....	0.514m³/s(50Hz),0.617m³/s(60Hz)
Voltage Regulation	±1.0%
Total Harmonic TGH / THCat no load < 1.5 % - on load < 5%	
Telephone Interference.....	THF<2%;TIF<50

PLC-920 Control System

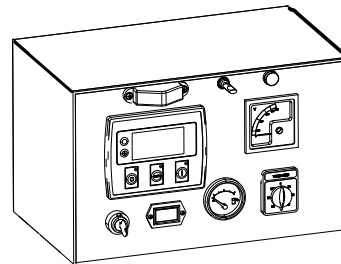

PLC-920 is an advanced control module based on micro-processor designed to control the engine via a key switch and push buttons on the front panel. The module is used to start and stop the engine and indicate fault conditions, automatically shutting down the engine and giving a true up fault condition of an engine failure.

Standard Control Function

- Manual Engine Control Module
- Low Oil Pressure
- High Engine Temperature
- Auxiliary Shutdown
- Overspeed Protection
- Protection hold-off timer
- Charge Failure warning

4 Overall Dimensions

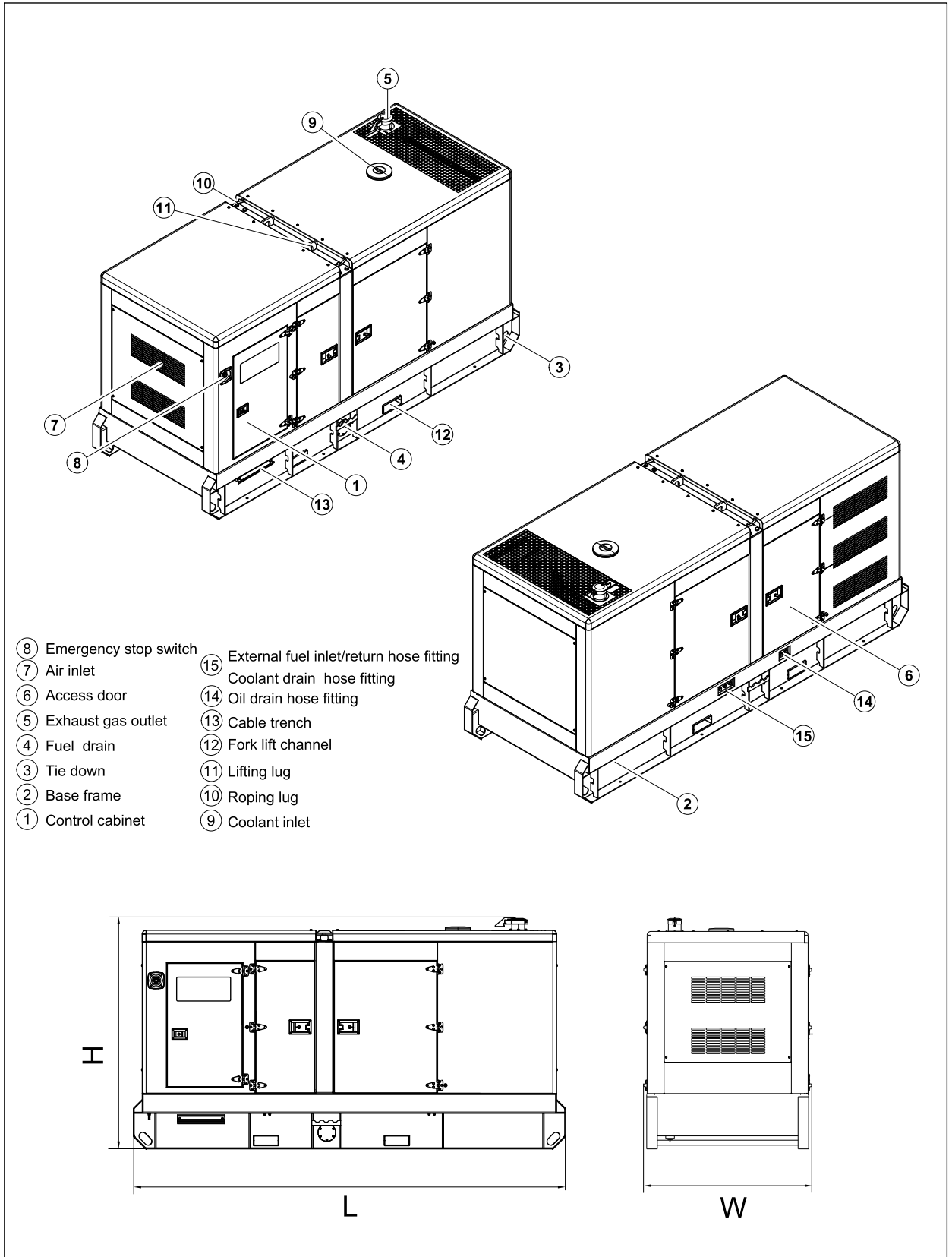

5 Control System

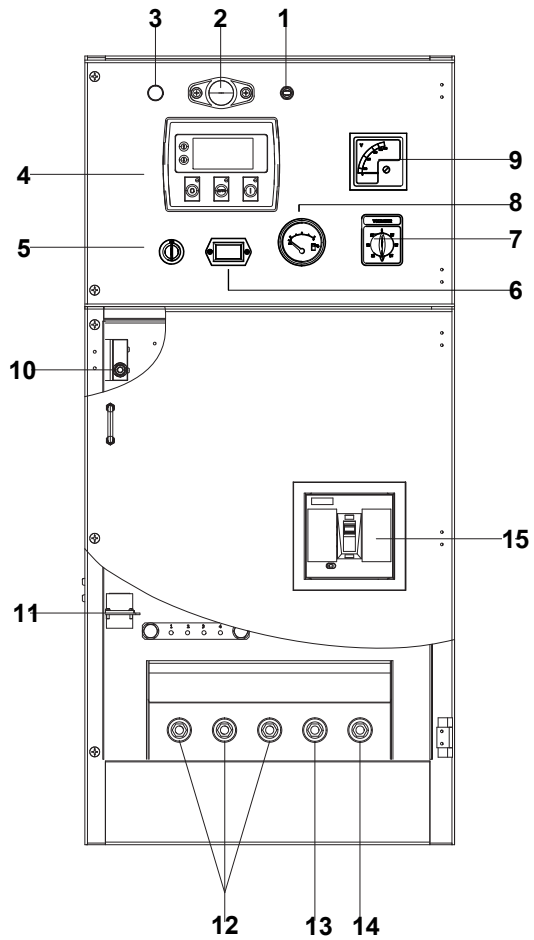

Control & field wiring cabinet

Ref.	Description
1	Control cabinet lamp switch
2	Control cabinet lamp
3	Charge indicator
4	Control module
5	Key switch
6	Time counter
7	Voltage changer-over switch
8	Fuel level meter
9	Voltage meter
10	Limit switch
11	Mains input/Remote control/ATS connector
12	Live wire terminal
13	Neutral wire terminal
14	Ground wire terminal
15	Main circuit breaker

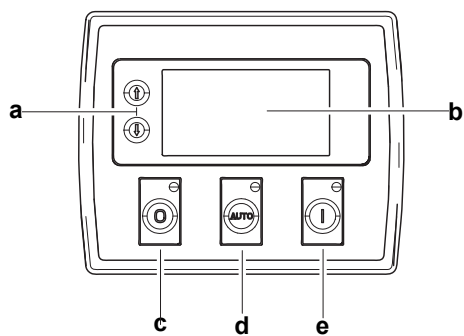

Control module

Ref.	Description
a	Navigation button«» Accept (Configuration mode only)
b	Main status display
c	Stop/reset button«» Next page (Configuration mode only)
d	Auto start button«» Decrease value/next item (Configuration mode only)
e	Start button«» Increase value/next item (Configuration mode only)

1000029547-A2-E

08.2023

<http://www.powerlinkgenset.com>
E-mail: info@powerlinkgenset.com

*Specification may change without prior notice. For more info.,
contact Power Link or your local distributors please.*