

Generator set
Containerized type
WCS1675S

SPECIFICATIONS

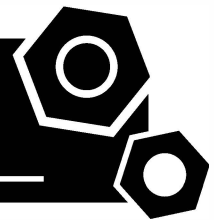

WCS series WCS1675S

50 Hz @ 1500rpm,3-phase/5-wiring



1 Standards & Conditions

Design Standards

The designs and the productions are in conformity with:

- Conformance Europeenne (CE)
- ISO8528-5:2005
- GB/T2820.5-2009

Environmental Operating Conditions

- Installation place: Outdoors or indoors (well ventilated).
- Ambient temperature: -25°C to 50°C. The coolant heater is needed when the temperature is below 5°C
- Humidity: Less than 80%.
- Altitude: Below one thousand (1000) meters.

Factory Inspection

- Inspection items.
- Protection devices working test.
- Starting ability in normal temperature.
- 50% rated power load moment capability.
- Voltage deviation and speed variation: 0%, 25%, 50%, 75%, 100%, 110% Load.

Painting Process

- Painting process specifications and colors are based on the manufacturer's standard.
- The customer could also choose the color which the manufacturer offers.

2 General Features

- Cummins engine KTA50GS8
- Close coupled to LSA alternator LSA50.2L8
- Microprocessor control module PLC-7420
- ABB main circuit breaker: 2500A
- Rotate speed governor: Electronic governor
- Excitation system: AREP
- Key switch
- Emergency stop switch
- ATS (automatic transfer switch) receptacle
- 4x12V/150AH sealed for life maintenance free battery
- Lockable battery isolator switch
- Powder coated canopy

- 50°C radiator
- Fire extinguisher
- Oil pump on the engine
- Steel base frame with forklifts
- Vibration isolators between the engine/alternator and base frame
- Dry type air filter
- Fuel tank for 7 hours running
- Drain points for fuel tank
- Fuel inlet pump and it's control box for the fuel tank
- Added fuel-water separator for fuel tank
- Operation Manual/ Specifications

3 Equipment Specification

General technical data

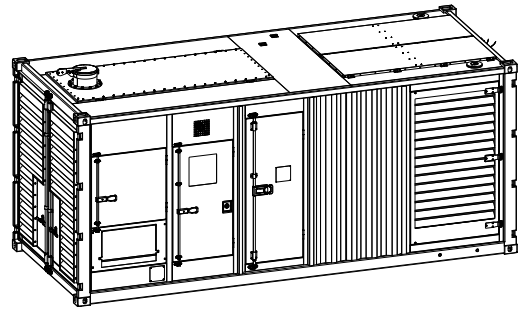

Model..... WCS1675S
 Structure type C
 Tank capacity..... 2400L
 Dry weight..... 16840kg
 Noise level @7m 80.0dBA
 Dimensions L×W×H.....6058×2438×2591mm
 Standby Power 1675kVA/1340kW
 Prime Power 1500kVA/1200kW

Voltage	380V	400V	415V	440V	
Ampere	2279A	2165A	2087A	1968A	
Genset Fuel Consumption					
Frequency/Load	25%	50%	75%	100%	110%
50Hz (L/h)	88	167	238	309	345

Diesel Engine

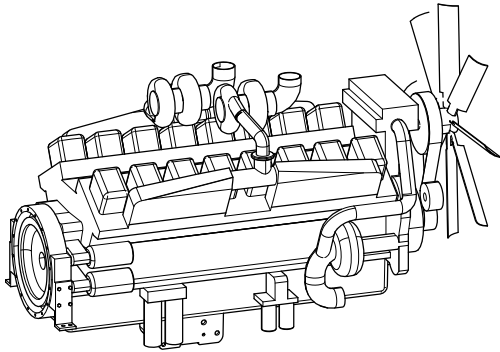

Engine Manufacturer/Brand.....	Cummins
Engine Model.....	KTA50GS8
Dimensions L×W×H.....	N/A
Dry Weigh (approx.)	5360Kg
Number of Cylinders.....	16
Bore	159mm
Stroke	159mm
Displacement.....	50.3L
Compression Ratio	14.9
Type of injection.....	Direct injection
Intake System.....	Turbocharged & Low Temp. Aftercooled
Intake Resistance	≤6.2kPa
Cooling System	Water cooled
Fan	Pusher
Battery Voltage	24V
Type of Fuel.....	No. 2 diesel or ASTM D2
Type of Oil	15W40 to API CG4
Oil Capacity	204L
Type of Coolant	Glycol mixture
Coolant Capacity (Engine Only).....	165L
Back Pressure	≤7kPa
Overload Power.....	1429kW
Prime Power	1287kW
Fuel Consumption(100%load).....	1287g/kW.h

Alternator

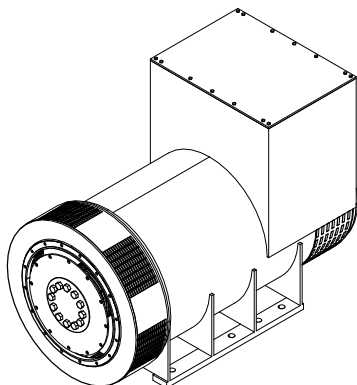

Alternator Manufacturer/Brand	LSA
Alternator Model	LSA50.2L8
Exciter.....	Brushless
Cooling Fan	Cast alloy aluminum
Windings.....	100% copper
Insulation Class	H
Winding Pitch.....	2/3
Terminals	6
Drip Proof	IP23
Altitude.....	≤1000m
Overspeed	2250rpm
Air Flow.....	2.69m³/s(50HZ),3.45m³/s(60HZ)
Voltage Regulation	±1.0%
Total harmonic TGH / THCat no load < 1.5 % - on load < 5%	
Telephone Interference.....	THF<2%;TIF<50

PLC-7420 Control System

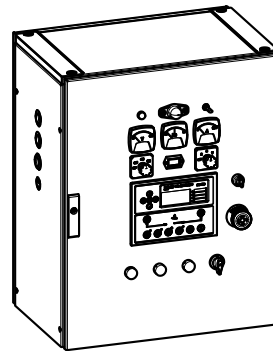

PLC-7420 is an advanced control module based on micro-processor, containing all necessary functions for protection of the genset and the breaker control. It can monitor the mains supply, and automatically start the engine when the mains is abnormal. Accurately measure various operational parameters and display all values and alarms information on the LCD. In addition, the control module can automatically shut down the engine and indicate the engine failure.

- Microprocessor control, with high stability and credibility
- Monitoring and measuring operational parameters of the mains supply and genset
- Indicating operation status, fault conditions, all parameters and alarms
- Multiple protections; multiple parameters display, like pressure, temp. etc.
- Manual, automatic and remote work mode selectable
- Real time clock for time and date display, overall runtime display, 250 log entries
- Overall power output display
- Integral speed/frequency detecting, telling status of start, rated operation, overspeed etc.
- Communication with PC via RS485 OR RS232 interface, using MODBUS protocol

5 Control System

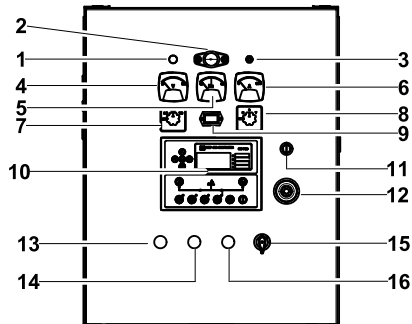

Control cabinet

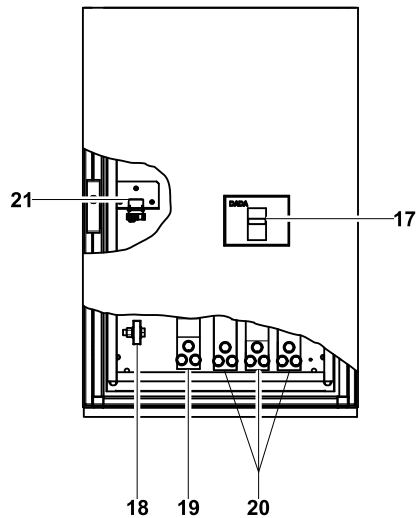

Field wiring cabinet

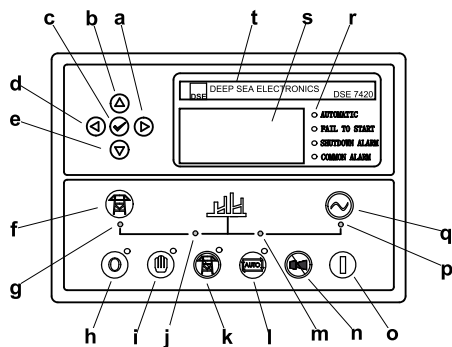

Control module

Ref.	Description
1	Charge indicator
2	Control cabinet lamp
3	Control cabinet lamp switch
4	Voltage meter
5	Frequency meter
6	Current meter
7	Changerover switch-Voltage
8	Changerover switch-Current
9	Time counter
10	Control module
11	Key switch
12	Emergency stop switch
13	Fuel leak indicator
14	Running button with indicator
15	Oil drain switch
16	Stop button with indicator
17	Main circuit breaker
18	Ground wire terminal
19	Neutral wire terminal
20	Live wire terminals
21	Mains input/Remote control/ ATS communication connector

a	Button (next page)
b	Button (increase value / previous item)
c	Button (accept)
d	Button (previous page)
e	Button (decrease value / next item)
f	Button (transfer the load to the mains supply, when in Manual mode only)
g	Mains supply available LED
h	Stop / Reset button
i	Manual button (Manual control mode)
j	Mains supply on load LED
k	Test button (Test mode)
l	Auto button (Auto mode)
m	Genset on load LED
n	Mute/Lamp test button
o	Start button (Manual)
p	Genset available LED
q	Button (transfer the load to the genset, when in Manual mode only)
r	Alarm LED (4 alarm items)
s	LCD display
t	Control module name

1000031068-A2-E

09.2023

<http://www.powerlinkworld.com>

*Specification may change without prior notice. For more info.,
contact Power Link or your local distributors please.*