

Generator set
Containerized type
B1000S

SPECIFICATIONS

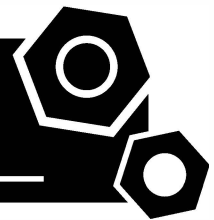

1 Standards & Conditions

Design Standards

The designs and the productions are in conformity with:

- Conformance Européenne (CE)
- ISO8528-5:2005
- GB/T2820.5-2009

Environmental Operating Conditions

- Installation place: Outdoors or indoors (well ventilated).
- Ambient temperature: -25°C to 45°C. The coolant heater is needed when the temperature is below 5°C
- Humidity: Less than 80%.
- Altitude: Below one thousand (1000) meters.

Factory Inspection

- Inspection items.
- Protection devices working test.
- Starting ability in normal temperature.
- 50% rated power load moment capability.
- Voltage deviation and speed variation: 0%, 25%, 50%, 75%, 100%, 110% Load.

Painting Process

- Painting process and colors are based on the manufacturer's standard.
- The customer could also choose the color which the manufacturer offers.

2 General Features

- Baudouin engine 12M26G1100/5
- Close coupled to Powerlink alternator PL6C
- Microprocessor control module PLC920
- Main circuit breaker: 1600A
- Rotate speed governor: ECU
- Excitation System: PMG
- A.V.R.Model: MX341
- Key switch
- Emergency stop switch
- ATS (automatic transfer switch) receptacle
- 4x12V/150AH sealed for life maintenance free battery
- Lockable battery isolator switch

- Powder coated canopy
- 50°C radiator
- Fire extinguisher
- Oil pump on the engine
- Steel base frame with forklots
- Vibration isolators between the engine/alternator and base frame
- Dry type air filter
- Fuel tank for 7 hours running
- Drain points for fuel tank
- Fuel inlet pump and control box for the fuel tank
- Added fuel-water separator for fuel tank
- Operation Manual / Specifications

3 Equipment Specification

General technical data

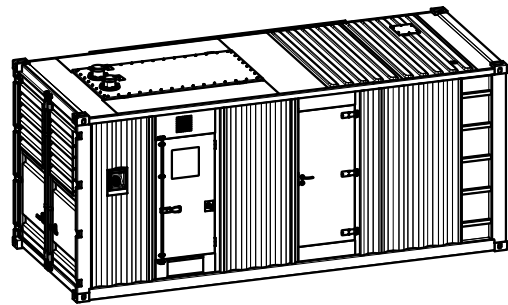

Model.....	B1000S
Structure type	C
Tank capacity.....	1600L
Dry weight.....	12600kg
Noise level @7m	79.2dBA
Dimensions L×W×H.....	6058x2438x2591mm
Standby Power	1100kVA/880kW
Prime Power.....	1000kVA/800kW

Voltage	380V	400V	415V		
Ampere	1519A	1443A	1391A		
Genset Fuel Consumption					
Frequency/Load	25%	50%	75%	100%	110%
50Hz (L/h)	58.4	106.6	155.3	207.1	228.1

Diesel Engine

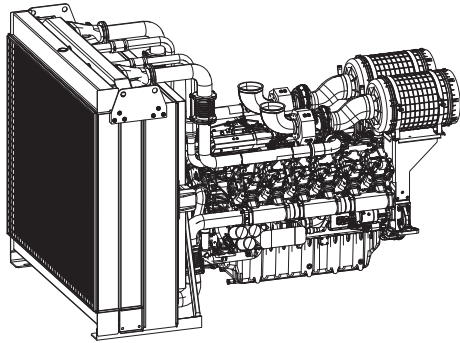

Engine Manufacturer/Brand.....	Baudouin
Engine Model.....	12M26G1100/5
Dimensions L×W×H.....	3162×1748×2150mm
Dry Weigh (approx.)	3585kg
Number of Cylinders.....	12
Bore.....	150mm
Stroke	150mm
Displacement.....	31.8L
Compression Ratio	15.7
Type of Injection	High Pressure Common Rail
Intake System.....	Turbocharged and aftercooled
Intake Resistance	≤6.5kPa
Cooling System	Water cooled
Fan	Pusher
Battery Voltage	24V
Type of Fuel.....	BS2869 class A2 or BS EN590
Type of Oil	API CH4 15W/40
Oil Capacity	109L
Type of Coolant	Glycol mixture
Coolant capacity	154L
Back Pressure	≤7.5kPa
Standby Power973kW
Prime Power889kW
Fuel Consumption(100%load)207.1L/h

Alternator

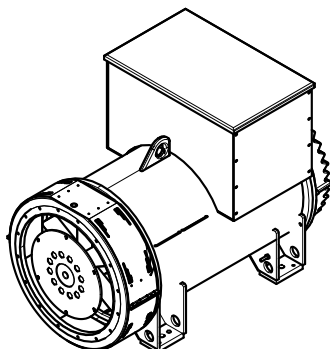

Alternator Manufacturer/Brand	Powerlink
Alternator Model	PL6C
Exciter.....	Brushless
Cooling Fan	Cast alloy aluminum
Windings.....	100% copper
Insulation Class	H
Winding Pitch	2/3
Terminals	6
Drip Proof	IP23
Altitude.....	≤1000m
Overspeed	2250rpm
Air Flow.....	1m³/s(50Hz), 1.2m³/s(60Hz)
Voltage Regulation	±0.5%
Total harmonic TGH / THC at no load < 4 % - on load < 4 %	
Telephone Interference.....	THF<2%;TIF<50

PLC-920 Control System

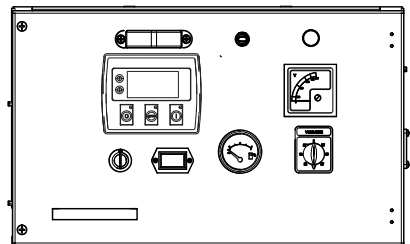

PLC-920 is an advanced control module based on micro-processor designed to control the engine via a key switch and push buttons on the front panel. The module is used to start and stop the engine and indicate fault conditions, automatically shutting down the engine and giving a true up fault condition of an engine failure.

Standard Control Function

- Manual Engine Control Module
- Low Oil Pressure
- High Engine Temperature
- Auxiliary Shutdown
- Overspeed Protection
- Protection hold-off timer
- Charge Failure warning

4 Overall Dimensions

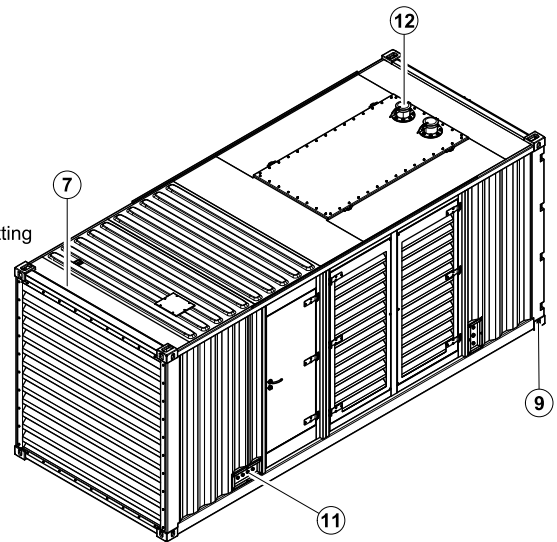
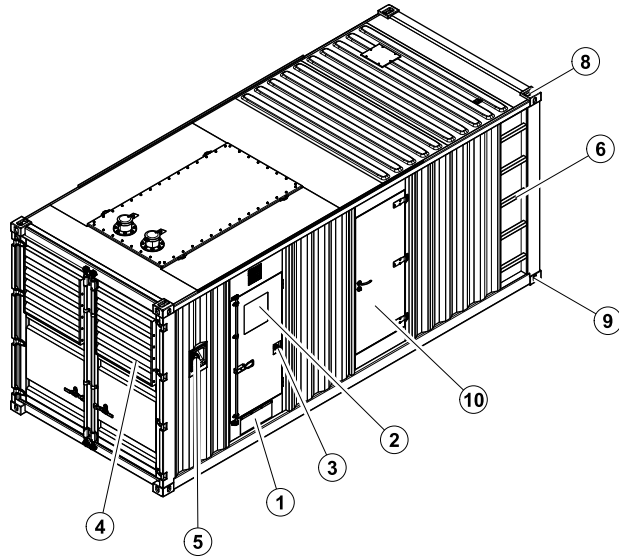

- | | |
|-------------------------|---|
| ⑥ Ladder | ⑫ Exhaust gas outlet |
| ⑤ Fuel inlet | ⑪ External fuel inlet/Return hose fitting
Coolant/Oil drain hose fitting |
| ④ Air inlet | ⑩ Access door |
| ③ Emergency stop switch | ⑨ Fixing lug |
| ② Control cabinet | ⑧ Lifting lug |
| ① Cable trench | ⑦ Canopy |

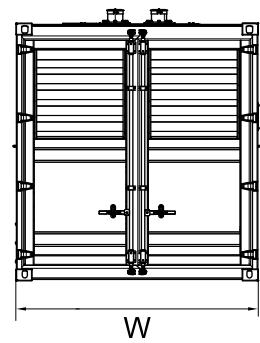
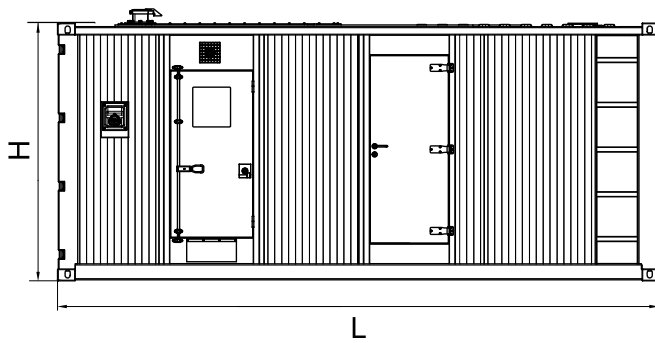

5 Control System

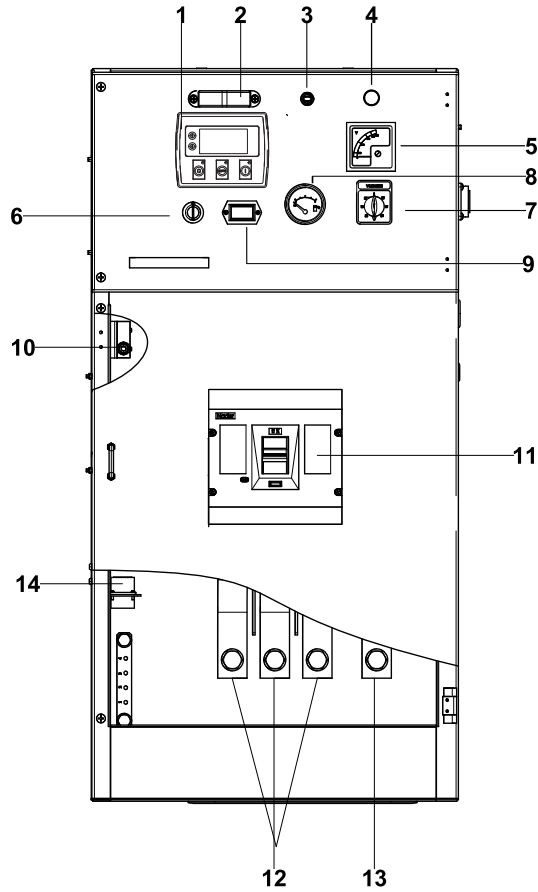

Control & field wiring cabinet

Ref.	Description
1	PLC-920 control module
2	Control cabinet lamp
3	Control cabinet lamp switch
4	Charge indicator
5	Voltage meter
6	Key switch
7	Voltage changer-over switch
8	Fuel level meter
9	Time counter
10	Limit switch
11	Main circuit breaker
12	Live wire terminal
13	Neutral wire terminal
14	Mains input/Remote control/ATS communication connector

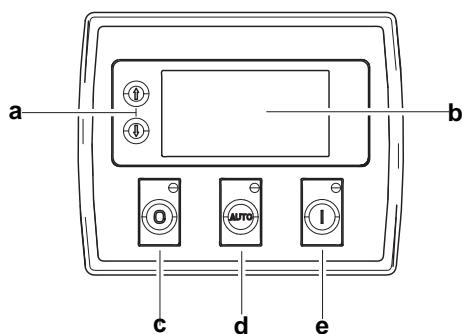

Control module

Ref.	Description
a	Navigation button « Accept (Configuration mode only)
b	Main status display
c	Stop/reset button « Next page (Configuration mode only)
d	Auto start button « Decrease value/next item (Configuration mode only)
e	Start button « Increase value/next item (Configuration mode only)

1000035954-A2-E

04.2023

<http://www.powerlinkworld.com>

*Specification may change without prior notice. For more info.,
contact Power Link or your local distributors please.*