

Generator set

Containerized type

WPS2250S-AU

SPECIFICATIONS

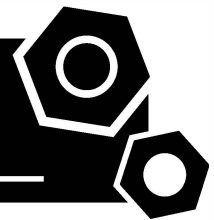

1 Standards & Conditions

Design Standards

The designs and the productions are in conformity with:

- Conformance Européenne (CE)
- ISO8528-5:2005
- AS 3000-2018
- AS 3010-2017

Environmental Operating Conditions

- Installation place: Outdoors or indoors (well ventilated).
- Ambient temperature: -25°C to 45°C. The coolant heater is needed when the temperature is below 5°C
- Humidity: Less than 80%.
- Altitude: Below one thousand (1000) meters.

Factory Inspection

- Inspection items.
- Protection devices working test.
- Starting ability in normal temperature.
- 50% rated power load moment capability.
- Voltage deviation and speed variation: 0%, 25%, 50%, 75%, 100%, 110% Load.

Painting Process

- Painting process specifications and colors are based on the manufacturer's standard.
- The customer could also choose the color which the manufacturer offers.

2 General Features

- Perkins engine 4016-61TRG3
- Close coupled to Leroy Somer alternator LSA52.3L9
- Microprocessor control module PLC-7420
- ABB main circuit breaker: 4000A
- Rotate speed governor: Electronic fuel injection governor
- Excitation System: AREP
- A.V.R.Model: R449
- Key switch
- Emergency stop switch
- ATS (automatic transfer switch) receptacle
- 2x12V/200AH sealed for life maintenance free battery
- Lockable battery isolator switch

- Powder coated canopy
- 50°C radiator
- Fire extinguisher
- Oil pump on the engine
- Steel base frame with forklifts
- Vibration isolators between the engine/alternator and base frame
- Dry type air filter
- Fuel tank for 5 hours running
- Drain points for fuel tank
- Fuel inlet pump and control box for the fuel tank
- Added fuel-water separator for fuel tank
- Operation Manual / Specifications

3 Equipment Specification

General technical data

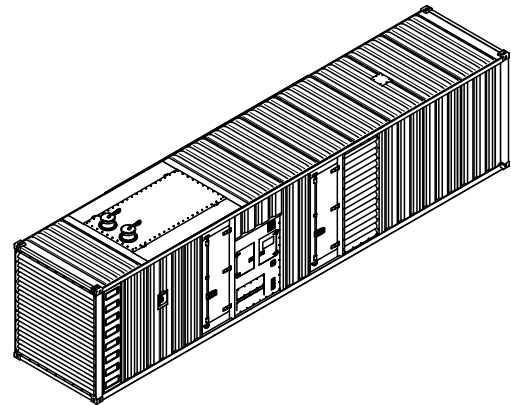

Model.....	WPS2250S-AU
Structure type	C
Tank capacity.....	2400L
Dry weight.....	25000kg
Noise level @7m	86.4dBA
Dimensions L×W×H.....	12192×2438×2896mm
Standby Power	2475kVA/1980kW
Prime Power	2250kVA/1800kW

Voltage	380V	400V	415V	440V	
Ampere	3419A	3248A	3130A	2952A	
Genset Fuel Consumption					
Frequency/Load	25%	50%	75%	100%	110%
50Hz (L/h)	145	246	349	470	529

Diesel Engine

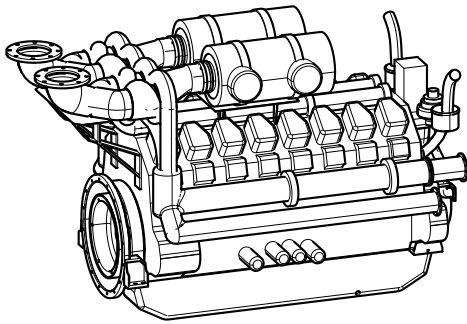

Engine Manufacturer/Brand.....	Perkins
Engine Model.....	4016-61TRG3
Dimensions L×W×H.....	4542×2185×2328mm
Dry Weigh (approx.).....	7783kg
Number of Cylinders.....	16
Bore.....	160mm
Stroke.....	190mm
Displacement.....	61.12L
Compression Ratio.....	13
Type of Injection.....	Direct injection
Intake System.....	Turbocharged
Intake Resistance.....	≤3.7kPa
Cooling System.....	Water cooled
Fan.....	Pusher
Battery Voltage.....	24V
Type of Fuel.....	BS2869 1998 Class A1, A2
Type of Oil.....	API CG4 15W/40
Oil Capacity.....	213L
Type of Coolant.....	Glycol mixture
Coolant capacity.....	260L
Back Pressure.....	≤6.6kPa
Standby Power.....	2183kW
Prime Power.....	1975kW
Fuel Consumption(100%load).....	470L/h

Alternator

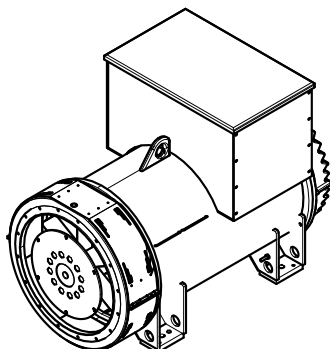

Alternator Manufacturer/Brand.....	Leroy Somer
Alternator Model.....	LSA52.3L9
Exciter.....	Brushless
Cooling Fan.....	Cast alloy aluminum
Windings.....	100% copper
Insulation Class.....	H
Winding Pitch.....	2/3
Drip Proof.....	IP23
Overspeed.....	2250rpm
Voltage Regulation.....	±0.5%
Total harmonic TGH / THC.....	< 2.5%
Telephone Interference.....	THF<2%;TIF<50

PLC-7420 Control System

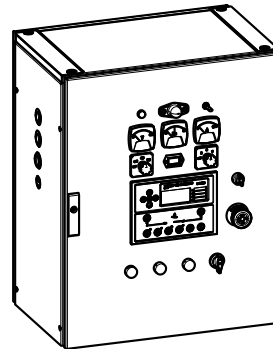

PLC-7420 is an advanced control module based on micro-processor, containing all necessary functions for protection of the genset and the breaker control. It can monitor the mains supply, and automatically start the engine when the mains is abnormal. Accurately measure various operational parameters and display all values and alarms information on the LCD. In addition, the control module can automatically shut down the engine and indicate the engine failure.

- Microprocessor control, with high stability and credibility
- Monitoring and measuring operational parameters of the mains supply and genset
- Indicating operation status, fault conditions, all parameters and alarms
- Multiple protections; multiple parameters display, like pressure, temp. etc.
- Manual, automatic and remote work mode selectable
- Real time clock for time and date display, overall runtime display, 250 log entries
- Overall power output display
- Integral speed/frequency detecting, telling status of start, rated operation, overspeed etc.
- Communication with PC via RS485 OR RS232 interface, using MODBUS protocol

4 Overall Dimensions

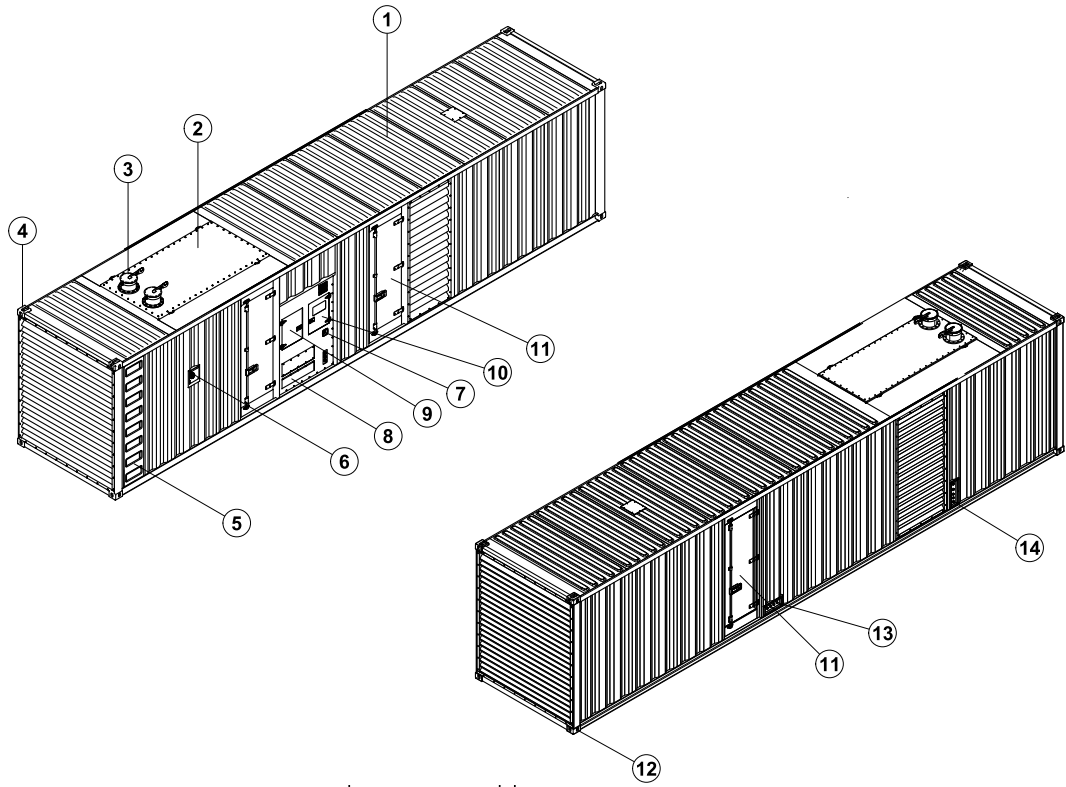

- | | |
|-------------------------|---|
| ⑦ Emergency stop switch | ⑭ External fuel inlet/return hose fitting |
| ⑥ Fuel inlet | ⑬ External fuel inlet/return hose fitting
Coolant/Oil drain hose fitting |
| ⑤ Ladder | ⑫ Fixing lug |
| ④ Lifting lug | ⑪ Access door |
| ③ Exhaust gas outlet | ⑩ Switch cabinet |
| ② Muffler | ⑨ Control cabinet |
| ① Canopy | ⑧ Cable trench |

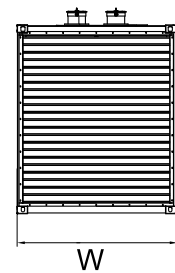
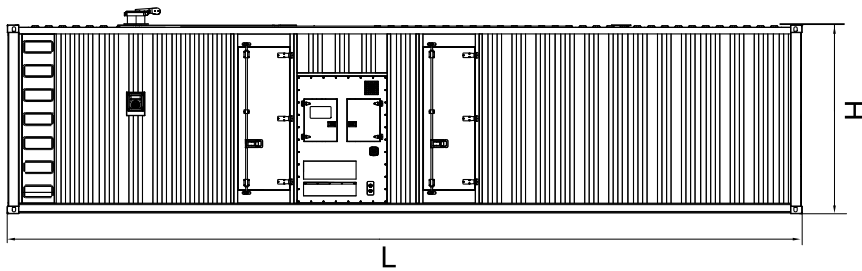

5 Control System

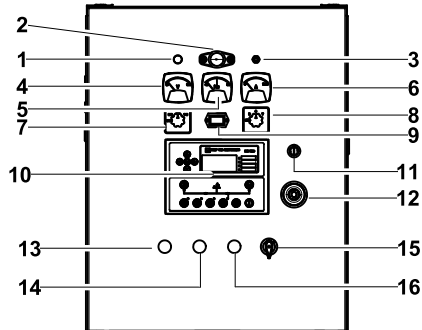

Control cabinet

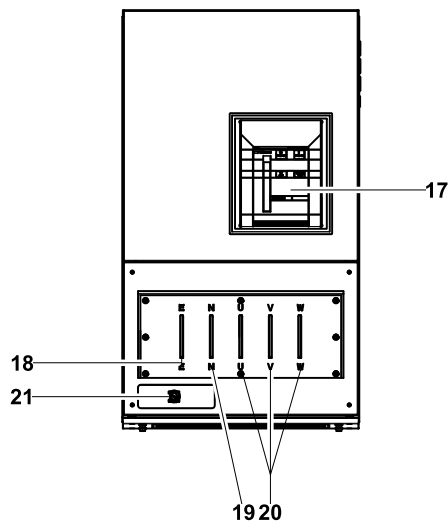

Field wiring cabinet

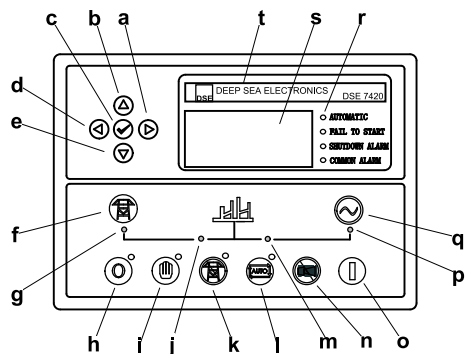

Control module

Ref.	Description
1	Control cabinet lamp
2	Control cabinet amp switch
3	Voltage meter
4	Frequency meter
5	Current meter
6	Changerover switch-Voltage
7	Changerover switch-Current
8	Time counter
9	Control module
10	Key switch
11	Emergency stop switch
12	Blue sea indicator
13	Running button with indicator
14	Oil drain switch
15	Stop button with indicator
16	Main circuit breaker
17	Ground wire terminal
18	Neutral wire terminal
19	Live wire terminals
20	Mains input/Remote control/RS communication connector
21	

a	Button (next page)
b	Button (increase value / previous item)
c	Button (accept)
d	Button (previous page)
e	Button (decrease value / next item)
f	Button (transfer the load to the mains supply, when in manual mode on y)
g	Mains supply available LED
	Stop / Reset button
i	Manual button (Manual control mode)
j	Mains supply on load
	Test button (Test mode)
l	Auto button (Auto mode)
m	Genset on load LED
n	Mute/amp test button
o	Start button (Manual)
p	Genset available LED
q	Button (transfer the load to the genset, when in Manual mode only)
r	Alarm LED (4 alarm items)
s	CD display
t	Control module name

1000021264-A2-E

11.2020

<http://www.powerlinkworld.com>

*Specification may change without prior notice. For more info.,
contact Power Link or your local distributors please.*