





EUPS500

UNINTERRUPTIBLE POWER SUPPLY SYSTEM

SPECIFICATION



EUPS500 Uninterruptible Power Supply System				
Item	Unit	Data		
Output power	kVA/kW	500/500		
Frequency	Hz	50		
Phase	P	3		
Power factor	PF	1		
Dimensions	mm	4650x2300x2500		
Dry weight	kg	14240		
40' Loading	Qty	2		
Protection class		IP54		
Noise level	dBA@7m	58		
Voltage	AC V	380	400	415
Current	A	760	722	696
Wiring port		L1、L2、L3、N、PE		
Voltage regulation range		±1%		
Load adaptation characteristics		Inductive load, resistive load		
Power connection input		AC socket: 3P/4W, 1x500kW		
Power connection output		AC socket: 3P/4W, 1x500kW		
Certification standards		<div style="display: flex; align-items: flex-start; gap: 20px;"> <div style="text-align: center;">  <p>UN38.3 PASSED Transport Safety Certified</p> </div> <div style="text-align: center;">  <p>ISO 9001</p> </div> <div style="text-align: center;">  <p>CE</p> </div> <div style="text-align: center;">  <p>IEC</p> </div> <div style="flex-grow: 1;"> <p>UN 38.3 IEC 62619 IEC 62477 IEC / EN 60529 EN 61000-6-1/2/3/4 AS 4777.2 G99 CE Declaration of Conformity</p> </div> </div>		

Classified Document

2024.12.12

Intelligent Energy Management

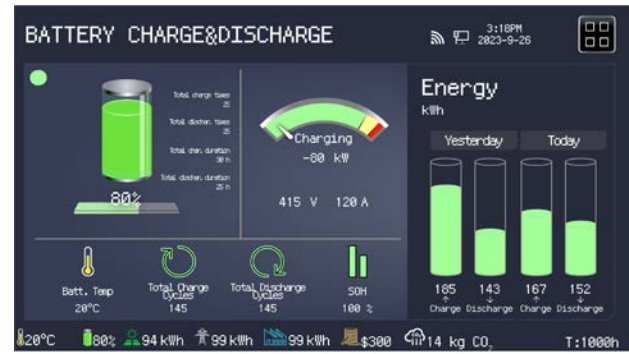

System Working Principle

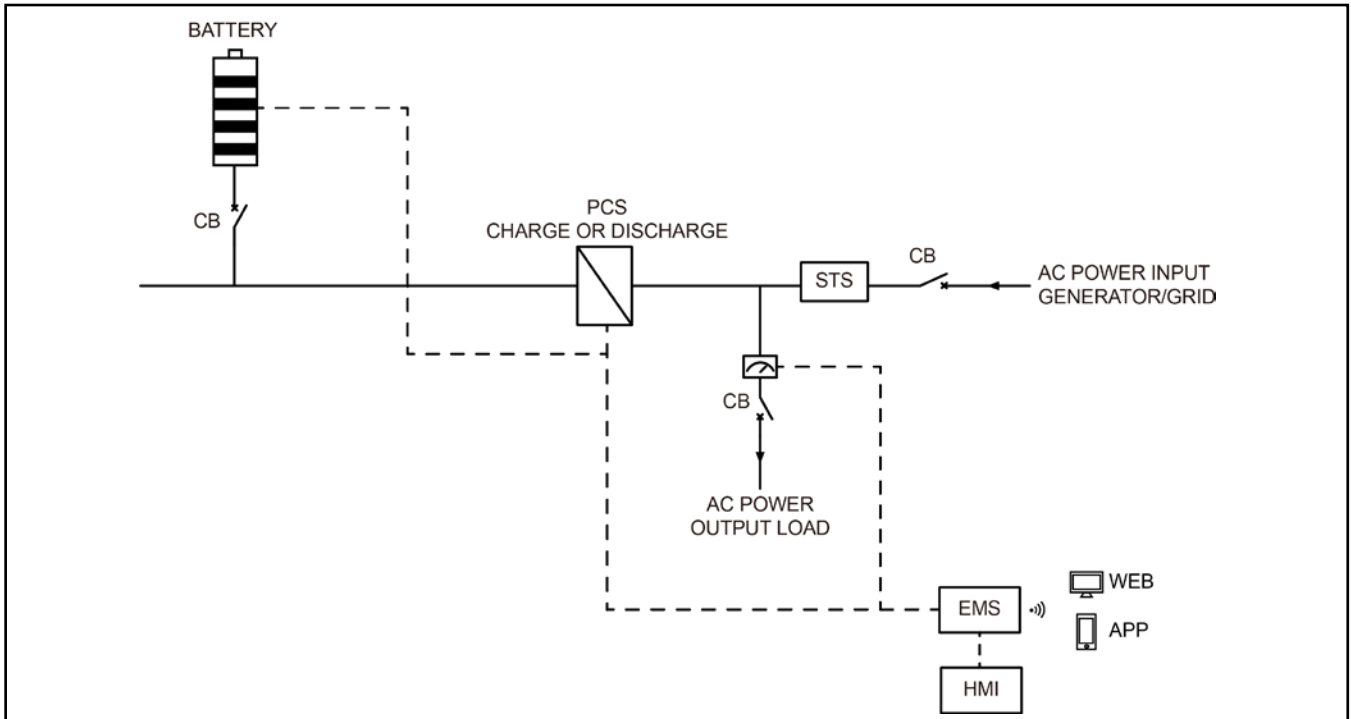

DC/AC System		
Rated power	kVA/kW	500/500
Output voltage	AC V	380/400/415

Grid Power Input		
Rated power	kVA/kW	500/500
Phase	P	3

Battery System		
Battery type		LiFePO4
Battery capacity	kWh	576
Rated voltage	DC V	768
Cooling system		Air-cooled
Max charging rate		1C
Max discharging rate		1C
NOTE: The discharge power decreases as the battery SOC decreases.		

Control System		
HMI control panel	inch	13" Touchscreen
Communication interface		WAN/WIFI/SIM
Cloud services		APP/WEB

* Data is subject to change without prior notice as new products are always developed.
Please contact POWERLINK or local agent with any doubts or for more information.

Classified
Document
2024.12.12